

THERMOWELLS

Sanitary-Connected Thermowells

Sanitary-Connected Thermowells are offered in 316 stainless steel. The DW and DR series are welded constructions, and they are available in a variety of lengths, cap styles, cap sizes, and optional lagging extensions. Thermowells are supplied with a surface finish that meets or exceeds 32µin R_a. Surface finishes of 15µin R_a or better are available upon request. They are designed with standard 0.260" bore diameters to accommodate sensing elements with a 0.252" maximum diameter. These wells are available as separate components or as part of complete sensor assemblies.

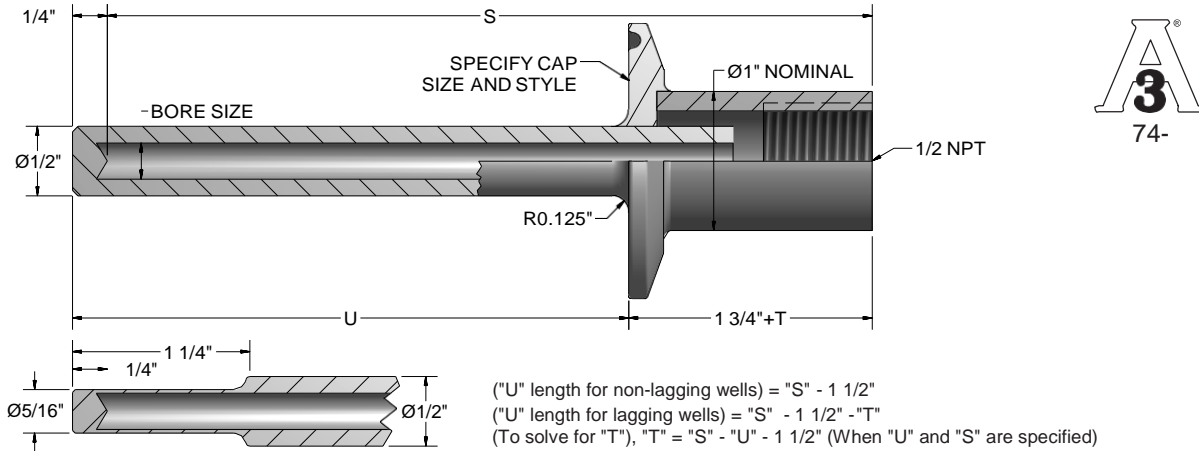

ORDER CODES

Example Order Number:

1-0 1-1 1-2 1-3 1-4 1-5 1-6
DW 4 25 09 08 T2 C8S

1-0 Well Type

CODE	DESCRIPTION
DW	Sanitary well
DR	Reduced-tip sanitary well

1-1 Bore Size

CODE	DESCRIPTION
4	0.260" Dia. bore

1-2 Cap Size & Style

CODE	DESCRIPTION
15	1", 1 1/2" Tri-clamp [®] 16 AMP
25	2" Tri-clamp [®] 16 AMP
35	2 1/2" Tri-clamp [®] 16 AMP
45	3" Tri-clamp [®] 16 AMP
Other styles - sizes available. Consult factory.	

Tri-clamp[®] is a registered trademark of Alfa Laval, Inc.

1-6 Options

CODE	DESCRIPTION
C8	316 stainless steel well cap and chain
S	Well stamped with customer-specified part number

1-5 Optional "T" Lag Dimension

CODE	DESCRIPTION
	Leave blank if no lag is required
T_	Specify "T" dimension in inches

1-4 Material

CODE	DESCRIPTION
08	316 stainless steel

1-3 "S" Length

CODE	DESCRIPTION
XX	Specify length in inches using two digits plus fractional length